

Isotherm Cooling Units

Indel Webasto Marine provides different solutions to cool at best some custom volumes using air or seawater for efficient heat removal.

Cooling Units

Isotherm Cooling Units	70
<hr/>	
Core Components	72
<hr/>	
Control elements	73
<hr/>	
ITC+	74
<hr/>	
Cooling System	78
<hr/>	
Air-cooled	80
Water-cooled SP	84
Water-cooled Magnum	87
ITC+	89

Isotherm Cooling Units

An innovative modular concept

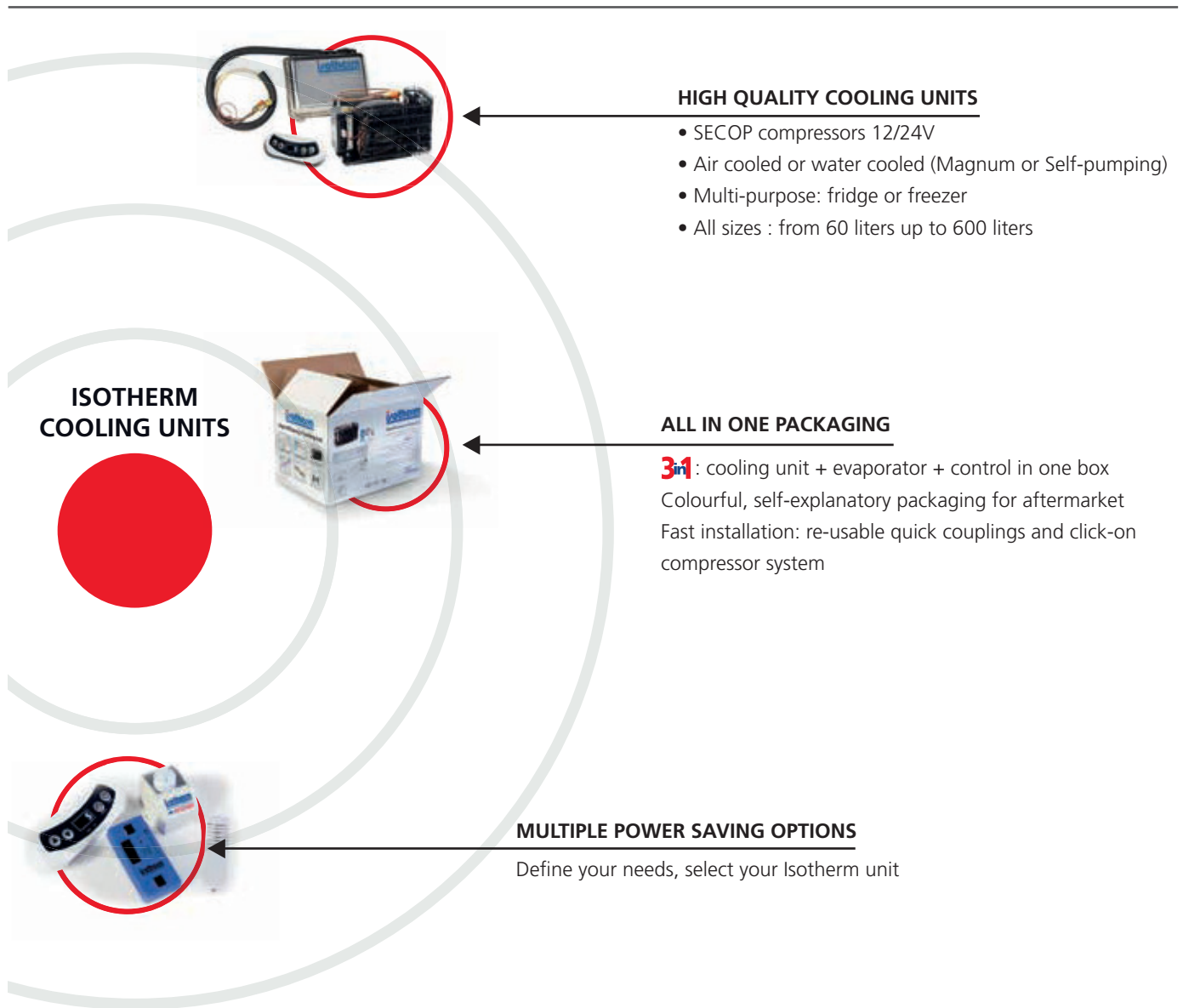

SELECTION MATRIX

Type	Control Interface	Energy Saving	Fast Cooling	Functions
Isotherm	Mechanical	O	++	
ITC	Digital	++	++	1.Dynamic control of battery charging status 2. Standard energy savings (overcooling, fixed compressor speeds) 3. Eco mode to extend battery autonomy 4.AC and/or DC applications possible
ITC+	Digital	+++	+	
SEC	Electronic	++++	+++	1.Full modulation of compressor speed 2.Advanced parameter settings to maximize energy savings 3.High energy savings without need for cold storage device 4.DC application only

Isotherm Cooling Units

Ready to match any demand

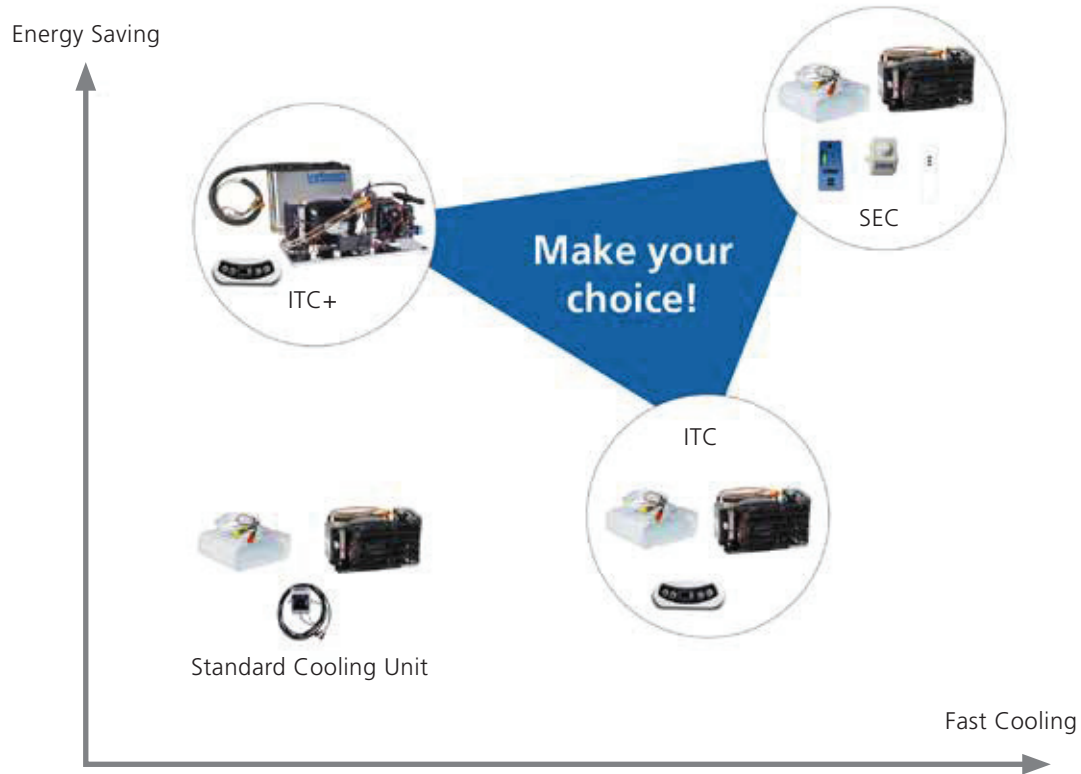

ITC: Intelligent Temperature Control
SEC: Smart Energy Control



Isotherm Cooling Units

Core Components

The best and widest product range available on the market!

The Indel Webasto Marine product portfolio with regards to cooling units, represents the most technologically advanced and complete selection available on the market. Capable to match any demand, it ranges from 60 to 600 liters of cooling capacity, being extremely flexible in product customization. Free your layouts and get maximum benefits of your on board space with Isotherm cooling units!

The Secop compressors are now even more power efficient! Hermetically sealed, extremely quiet running and reliable, they are specifically tuned for Indel Webasto Marine applications. The three-phase current is created in a small microprocessor, where Indel Webasto Marine has been able to program a number of functions which check and control many of the unit systems. This allows achieving the lowest possible power consumption. The same compressor is used both for 12 V and 24 V systems and the electronic unit is able to protect itself from accidental reversal of the voltage polarity. Universal AC/DC kit available as optional, to allow sufficient power supply all around the world.

A wide range of evaporators, exclusive Isotherm know-how, allow an unbeatable product performance and flexible on board application. The variety of controls matches any customer demands and ensures the lowest power consumption on the market.

Feel free to select the best way to dissipate heat based on your application's constrain, via air or water cooling. As a final step, select the best control system based on your application needs, with the unique plus of being delivered with a self-explanatory all-in-one packaging! (Only for premium products as SEC, ITC and ITC+).



Re-Usable Quick couplings

All cooling units are equipped with the new type of quick couplings, that can be disconnected without any gas leaking like the former versions.

In addition to the above, the valve assembly inside the coupling's body can be easily replaced, without welding operations.



Practical click-on mounting bracket

A practical click-on mounting bracket suitable for horizontal or vertical wall installation, is included in all models except the Magnum models.

Fasten the bracket and lift the compressor into place. „Click“! The compressor locks onto the bracket without adjustments or tools.



Isotherm Cooling Units

Control Elements



The mechanical thermostat represents the standard control element of the cooling unit program, being reliable and easy to use for boat owners. It is allowing a fast cooling process of the compartment representing, managing compressor's activation on a basic on/off command.

The ITC Digital Display (Intelligent Temperature Control) clearly shows, controls and regulates the temperature in a refrigerated compartment from the exterior of a fridge/freezer cabinet. It is dedicated to people that desire a nice-looking interface and a professional product interaction, as well as reduce the on board power consumption thanks to its specific factory settings. (ITC, Eco and overcooling mode) a dedicated Air sensor always provides accurate readings and the user can chose among three different battery's protection levels. The ITC Digital Display in conjunction with a Holding Plate forms a cooling unit called ITC+, where the storing energy effect is amplified thanks to the huge range of plates available.



The Smart Energy Control (SEC) is a sophisticated processor-based control device, that achieves significant power consumption by continuously scanning a set of key environmental factors, to operate the compressors at their best performance/battery drain ratio. Via the storage function in food and drinks can achieve up to 50% savings Vs. conventional control systems, representing the best answers for users hunting for the lowest power consumption.

Isotherm Cooling Units

ITC+

NEW

The ITC+ technology represents the best in terms of both cooling performances and temperature control, since the typical features of the ITC digital panel are enhanced by the storing energy effect of the eutectic plate.

The control logic detects when a surplus of power is available, uses this power to freeze the cooling plate which consequently stores the cold for times, when no power is available for cooling purposes.

A high-quality Secop compressor builds the core of the ITC+, together with the Isotherm holding plate and the exclusive electronic control system being an unbeatable combination.

How much power is needed?

This is the most frequently asked question of all.

We can give exact power consumption figures for our range of refrigerators, freezers and boxes, as we know their size and quality of insulation. It is more difficult to quote a figure for self-installed refrigeration boxes as we do not know the exact size of the box, or even more important, the quality and thickness of the insulation material used.



ITC+

The intelligent refrigerator charges the holding plate while the engine is running by means of the patented energy management system.



- Low power consumption
- Digital interface with accurate display of temperature
- Fridge or freezer (-12°C)
- 12/24 V Secop compressor
- Kit AC / DC optional for a complete power supply compatibility
- Easy installation thanks to "click-on" system



- Low power consumption
- Digital interface with accurate display of temperature
- Fridge or freezer (-12°C)
- 12/24 V Secop compressor
- Kit AC / DC optional for a complete power supply compatibility
- Easy installation thanks to "click-on" system
- SP system (patented) to reduce noise of standard fan cooled condenser systems



- Low power consumption
- Digital interface with accurate display of temperature
- Fridge or freezer (-12°C)
- 12/24 V Secop compressor
- Kit AC / DC optional for a complete power supply compatibility
- Self-priming seawater pump (variable speed) to ensure extra high efficiency for tropical applications



Isotherm Cooling Units

Cooling systems

Three possible cooling systems

Indel Webasto Marine provides a wide range of cooling units to suit every demand. For efficient heat removal various methods can be applied. Isotherm cooling units use air or seawater to eliminate the heat.



Self-pumping sea water-cooled

The Isotherm SP units cool with the use of seawater. This method has the advantage that the heat exchange is made via a water cooled condenser. The water-cooled Isotherm SP operates consistently at an extremely high level of efficiency. Without fans or pumps to remove the heat generated by the condenser, the SP system consumes less battery power and is remarkably quiet.

The Isotherm SP unit uses the movements of the hull to draw heat down and out through a special fitting in the galley sink drain hose. The flow is completely free inside the draining hose, so each movement of the surrounding water produces a similar quantity of water level inside the hose, which results in pumping an equivalent amount of water in and out. By designing a special hull fitting containing a non restricting, fullflow spiral heat exchanger for cooling the heated refrigeration agent, an extremely efficient cooling system is created.

As the hull fitting is situated away from the boat's center of gravity, the smallest movement of the hull or mast of sailing boat is sufficient to create a pumping action. This movement results in constant withdraw of warm water and intake of cold water which also prevents fouling.

- Fridge versions or freezer versions available
- 12/24 V Secop compressor
- Universal kit AC/DC optional for a complete power supply compatibility (12 / 24 V, 230/115 V and 50/60 Hz)
- Easy installation thanks to "click-on" system on DC models
- SP system (patented) to reduce the noise of a ventilated condenser and reach a lower power consumption

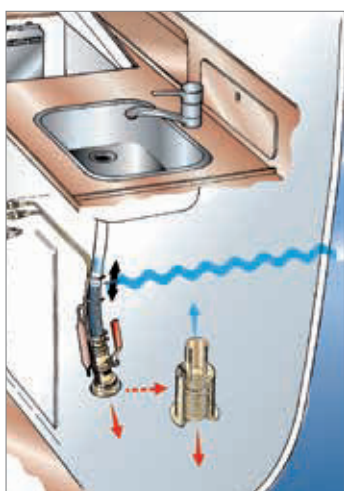

- Sea water cooling for even higher efficiency
- Lower power consumption
- Silent – no fan nor pumps
- Heat removed by sea water (max. temperature 28°C)
- No extra holes in hull required
- Simple to fit. Replaces the through-hull fitting for galley sink



Air-cooling

Using air which is blown through the condenser by a fan is the traditional way to remove the heat. It is important that the compressor compartment is well ventilated allowing cold air to enter from below and hot air to escape to the top.



- Fridge versions or freezer versions available
- 12/24 V Secop compressor
- Universal kit AC/DC optional for a complete power supply compatibility (12/24 V, 230/115 V and 50/60 Hz)
- Easy installation thanks to "click-on" system on DC models



Isotherm Magnum – Seawater cooled electric pump

Isotherm Magnum units are especially designed for vessels with exceptionally high refrigeration requirements, for example vessels sailing in tropical waters. Isotherm Magnum uses the surrounding water to increase cooling efficiency. All Magnum models are fitted with integral seawater pumps for circulating the cooling water through the cooling section of the refrigerator compressor. The pump is quiet, self-priming, withstands dry running and is self-aerating. The highly efficient heat exchanger is manufactured in a corrosion-resistant copper-nickel alloy and fitted with a zinc anode. Sea water-cooled units are extremely efficient and offer increased cooling capacity.

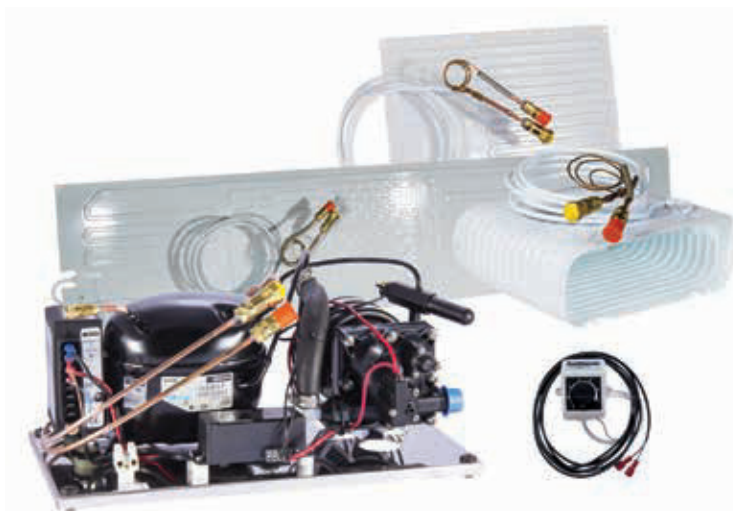

- Fridge versions or freezer versions available
- 12/24 V Secop compressor
- Universal kit AC/DC optional for a complete power supply compatibility (12/24 V, 230/115 V and 50/60 Hz)
- Self-priming sea water pump to ensure extra high efficiency for tropical applications
- Variable speed water pump according to the temperature of the water circulating inside the condenser

Isotherm Cooling Units

Fridge, Freezer, Fridge/Freezer

Technical Data:

System	Unit code	Max Volume (l)		Dimensions evaporator (mm)	Dimensions compressor W x H x D (mm)	Weight (kg)	Secop Compressor type	Control
		Fridge	Freezer					
Fridge								
Air-cooled	U060X000P11111AA	60	-	"Flat" 350 x 130	280 x 160 x 175	9	BD35F	Mechanical
Air-cooled	U080X000P11111AA	80	-	"Flat" 350x250	280 x 160 x 175	9	BD35F	Mechanical
Air-cooled	U100X000L11111AA	100	-	"L" 250 x 110 x 350	280 x 160 x 175	12	BD35F	Mechanical
Water-cooled SP	U100X000L11311AA	100	-	"L" 250 x 110 x 350	280 x 160 x 175	14	BD35F	Mechanical
Air-cooled	U100X000L11111AC	100	-	"L" 270 x 95 x 250	280 x 160 x 175	10	BD35F	Mechanical
Air-cooled	U125X000L11111AA	125	-	"L" 400 x 170 x 210	280 x 160 x 175	9	BD35F	Mechanical
Water-cooled SP	U125X000L11311AA	125	-	"L" 400 x 170 x 210	280 x 160 x 175	11	BD35F	Mechanical
Air-cooled	U125X000R11111AA	125	-	"Oval" 240 x 210 x 85	280 x 160 x 175	9	BD35F	Mechanical
Water-cooled SP	U125X000R11311AA	125	-	"Oval" 240 x 210 x 85	280 x 160 x 175	11	BD35F	Mechanical
Air-cooled	U150X000P11111AA	150	-	"Flat" 386 x 361	280 x 160 x 175	9	BD35F	Mechanical
Air-cooled	U150X000R11111AA	150	-	"Oval" 320 x 100 x 230	280 x 160 x 175	9	BD35F	Mechanical
Air-cooled	U150X000R11111AB	150	-	"Oval" 320 x 100 x 230	280 x 160 x 175	9	BD35F	Mechanical
Air-cooled	U150X000F11111AA	150	-	275 x 220 x 70	280 x 160 x 175	10	BD35F	Mechanical
Water-cooled SP	U150X000R11311AA	150	-	"Oval" 320 x 100 x 230	280 x 160 x 175	11	BD35F	Mechanical
Air-cooled	U200X000R11111AA	200	-	"Oval" 380 x 140 x 270	330 x 160 x 175	9	BD50F	Mechanical
Freezer								
Water-cooled SP	U000X041L13311AA	-	41	"L" 400 x 170 x 210	280 x 160 x 175	12	BD35F	Mechanical
Air-cooled	U000X041R13111AA	-	41	"Oval" 240 x 110 x 85	280 x 160 x 175	16	BD35F	Mechanical
Air-cooled	U000X066R13111AA	-	66	"Oval" 380 x 140 x 270	330 x 160 x 175	16	BD50F	Mechanical
Air-cooled	U000X066P13111AA	-	66	"Flat" 1200 x 190	330 x 160 x 175	12	BD50F	Mechanical
Air-cooled	U000X086P13111AA	-	86	"Flat" 1000 x 270	330 x 160 x 175	12	BD50F	Mechanical
Air-cooled	U000X133P13111AA	-	133	"Flat" 1370 x 330	330 x 160 x 175	12	BD50F	Mechanical
Water-cooled Magnum	U000X141P13411AA	-	141	"Flat" 1370 x 330	420 x 240 x 400	15	BD80F	Mechanical
Water-cooled Magnum	U000X200P13411AA	-	200	"Flat" 1500 x 460	420 x 240 x 400	15	BD80F	Mechanical
Fridge/Freezer								
Air-cooled	U060X020P17161AA	60	20	"Flat" 350 x 130	280 x 160 x 175	9	BD35F	ITC
Air-cooled	U060X020P17151AA	60	20	"Flat" 350 x 130	280 x 160 x 175	9	BD35F	SEC
Air-cooled	U080X026P17161AA	80	26	"Flat" 350 x 130	280 x 160 x 175	9	BD35F	ITC
Air-cooled	U080X026P17151AA	80	26	"Flat" 350 x 130	280 x 160 x 175	9	BD35F	SEC
Air-cooled	U100X033L17161AA	100	33	"L" 250 x 110x 350	280 x 160 x 175	14	BD35F	ITC
Air-cooled	U100X033L17151AA	100	33	"L" 250 x 110x 350	280 x 160 x 175	14	BD35F	SEC
Air-cooled	U125X041L17161AA	125	41	"L" 400 x 170 x 210	280 x 160 x 175	9	BD35F	ITC
Air-cooled	U125X041L17151AA	125	41	"L" 400 x 170 x 210	280 x 160 x 175	9	BD35F	SEC
Air-cooled	U125X041R17161AA	125	41	"Oval" 240 x 210 x 85	280 x 160 x 175	9	BD35F	ITC
Air-cooled	U125X041R17151AA	125	41	"Oval" 240 x 210 x 85	280 x 160 x 175	9	BD35F	SEC
Air-cooled	U150X050P17161AA	150	50	"Flat" 386 x 361	280 x 160 x 175	9	BD35F	ITC
Air-cooled	U150X050R17161AA	150	50	"Oval" 320 x 100 x 230	330 x 160 x 175	9	BD50F	ITC
Air-cooled	U150X050R17151AA	150	50	"Oval" 320 x 100 x 230	330 x 160 x 175	9	BD50F	SEC
Water-cooled Magnum	U200X066R12411AA	200	66	"Oval" 380 x 140 x 270	420 x 240 x 200	15	BD50F	Dual
Air-cooled	U200X066P12111AA	200	66	"Flat" 1200 x 190	330 x 160 x 175	12	BD50F	Dual
Air-cooled	U260X086P12111AA	260	86	"Flat" 1000 x 270	330 x 160 x 175	11	BD50F	Dual
Water-cooled Magnum	U260X086P12411AA	260	86	"Flat" 1000 x 270	420 x 240 x 200	14	BD50F	Dual
Air-cooled	U400X133P12111AA	400	133	"Flat" 1370 x 300	330 x 160 x 175	12	BD50F	Dual
Water-cooled Magnum	U400X133P12411AA	400	133	"Flat" 1370 x 300	420 x 240 x 200	16	BD50F	Dual
Air-cooled	U170X056P12111AA	170	56	"Flat" 815 x 210	330 x 160 x 175	11	BD50F	Dual
Air-cooled	U170X056P17161AA	170	56	"Flat" 815 x 210	330 x 160 x 175	11	BD50F	ITC

Isotherm Cooling Units

Fridge/Freezer ITC+

NEW

Technical Data:

System	Unit code	Max Volume (l)		Holding Plate (l)	Dimensions compressor W x H x D (mm)	Weight (kg)	Secop Compressor type	Control
		Fridge	Freezer					
Fridge/Freezer		Fridge	Freezer					
Air cooled	U100X035A17161AA	100	35	2	280 x 160 x 175	14	BD35F	ITC+
Air cooled	U150X050A17161AA	150	50	3	330 x 160 x 175	16	BD50F	ITC+
Air cooled	U200X065A17161AA	200	65	6	330 x 160 x 175	16	BD50F	ITC+
Water-cooled Magnum	U150X050A17461AA	150	50	3	420 x 240 x 200	19	BD50F	ITC+
Water-cooled SP	U100X035A17361AA	100	35	2	280 x 160 x 175	14	BD35F	ITC+
Water-cooled SP	U150X050A17361AA	150	50	3	420 x 240 x 200	18	BD50F	ITC+

IPN Intelligent Part Numbering

With the Isotherm IPN system (Intelligent Part Numbering) will be extremely easy to configure your cooling system for the best customization! The self-explanatory part number structure is capable to clearly specify units' characteristics at a glance, by simply reading it.

The structure is made by 16 digits, with the first 8 dedicated to explain:

- Function (fridge, freezer or fridge freezer)
- Maximum liters capacity (as fridge or freezer, according to minimum insulation requirements as per Isotherm specifications)

IPN Isotherm system, your cooling unit has never been so easy to understand and configure!

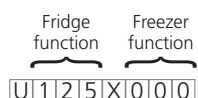

U125X000 In this case the unit is a FRIDGE - with maximum 125 lt. capacity

U125X041 In this case the unit is a FRIDGE - FREEZER - with maximum 125 lt. capacity as fridge and 41 lt. as freezer

U000X041 In this case the unit is a FREEZER - with maximum 41 lt. capacity

Air-cooled

Cooling Unit BD35F base

Select your control



Mechanical



ITC



SEC

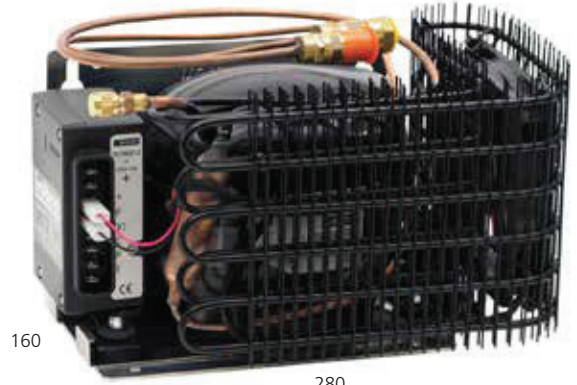

160

280

175

SPECIFICATIONS

Evaporator	Flat
Max. Box Volume Fridge (l)	60
Max. Box Volume Freezer (l)	20



350

130

FUNCTION	UNIT CODE	DESCRIPTION	CONTROL
Fridge	U060X000P11111AA	FRIDGE UNIT 60L FLAT EVAPORATOR 350x130mm 12/24V DC(2005)	Mechanical
Fridge/freezer	U060X020P17161AA	FRIDGE/FREEZER UNIT 60/20L FLAT EVAPORATOR 350x130mm 12/24V DC ITC (2005)	ITC
Fridge/freezer	U060X020P17151AA	FRIDGE/FREEZER UNIT 60/20L FLAT EVAPORATOR 350x130mm 12/24V DC SEC (2005)	SEC

SPECIFICATIONS

Evaporator	Flat
Max. Box Volume Fridge (l)	80
Max. Box Volume Freezer (l)	26



350

250

CATEGORY	UNIT CODE	DESCRIPTION	CONTROL
Fridge	U080X000P11111AA	FRIDGE UNIT 80L FLAT EVAPORATOR 350x250mm 12/24V DC (GE80)	Mechanical
Fridge/freezer	U080X026P17161AA	FRIDGE/FREEZER UNIT 80/26L FLAT EVAPORATOR 350x250mm 12/24V DC ITC (GE80)	ITC
Fridge/freezer	U080X026P17151AA	FRIDGE/FREEZER UNIT 80L/26L FLAT EVAPORATOR 350x250mm 12/24V DC SEC (GE80)	SEC

SPECIFICATIONS

Evaporator	L
Max. Box Volume Fridge (l)	100
Max. Box Volume Freezer (l)	33



350

250

110

CATEGORY	UNIT CODE	DESCRIPTION	CONTROL
Fridge	U100X000L11111AA	FRIDGE UNIT 100L "L" BENT EVAPORATOR 250+110x350mm 12/24V DC (2007)	Mechanical
Fridge/freezer	U100X033L17161AA	FRIDGE/FREEZER UNIT 100/33L "L" BENT EVAPORATOR 250+110x350mm 12/24V DC ITC (2007)	ITC
Fridge/freezer	U100X033L17151AA	FRIDGE/FREEZER UNIT 100/33L "L" BENT EVAPORATOR 250+110x350mm 12/24V DC SEC (2007)	SEC

Air-cooled

Cooling Unit BD35F base

Select your control



Mechanical



ITC



SEC

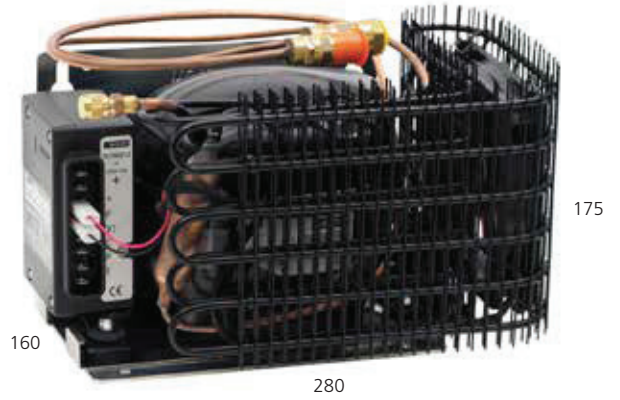

SPECIFICATIONS	
Evaporator	L
Max. Box Volume Fridge (l)	100

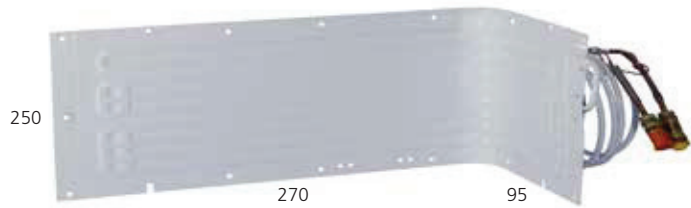

CATEGORY	UNIT CODE	DESCRIPTION	CONTROL
Fridge	U100X000L11111AC	FRIDGE UNIT 100L "L" BENT EVAPORATOR 270+95x250mm 12/24V DC (2018)	Mechanical

SPECIFICATIONS	
Evaporator	L
Max. Box Volume Fridge (l)	125
Max. Box Volume Freezer (l)	41

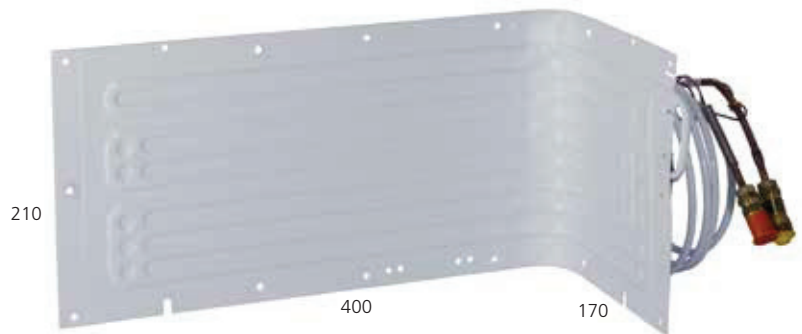

CATEGORY	UNIT CODE	DESCRIPTION	CONTROL
Fridge	U125X000L11111AA	FRIDGE UNIT 125L BIG "L" BENT EVAPORATOR 400+170x210mm 12/24V DC (2010)	Mechanical
Fridge/freezer	U125X041L17161AA	FRIDGE/FREEZER UNIT 125/41L "L" BENT BIG EVAPORATOR 400+170x210mm 12/24V DC ITC (2010)	ITC
Fridge/freezer	U125X041L17151AA	FRIDGE/FREEZER UNIT 125L/41L BIG "L" BENT EVAPORATOR 400+170x210mm 12/24V DC SEC (2010)	SEC

SPECIFICATIONS	
Evaporator	O
Max. Box Volume Fridge (l)	125
Max. Box Volume Freezer (l)	41



CATEGORY	UNIT CODE	DESCRIPTION	CONTROL
Fridge	U125X000R11111AA	FRIDGE UNIT 125L OVAL EVAPORATOR 4L 240x210x85mm 12/24V DC (2001)	Mechanical
Freezer	U000X041R13111AA	FREEZER UNTI 41L OVAL EVAPORATOR 4L 240x210x85mm 12/24 DC (2001)	Mechanical
Fridge/freezer	U125X041R17161AA	FRIDGE/FREEZER UNIT 125/41L OVAL EVAPORATOR 4L 240x210x85mm 12/24V DC ITC (2001)	ITC
Fridge/freezer	U125X041R17151AA	FRIDGE/FREEZER UNIT 125/41L OVAL EVAPORATOR 4L 240x210x85mm 12/24V DC SEC (2001)	SEC

Air-cooled

Cooling Unit BD35F base

Select your control



Mechanical



ITC



SEC



160

280

175

SPECIFICATIONS

Evaporator	Flat
Max. Box Volume Fridge (l)	150
Max. Box Volume Freezer (l)	50



386

361

FUNCTION	UNIT CODE	DESCRIPTION	CONTROL
Fridge	U150X000P11111AA	FRIDGE UNIT 150L FLAT EVAPORATOR 386x361mm 12/24V DC (GE150)	Mechanical
Fridge/freezer	U150X050P17161AA	FRIDGE/FREEZER UNIT 150/50L FLAT EVAPORATOR 386x361mm 12/24V DC ITC (GE150)	ITC

SPECIFICATIONS

Evaporator	O
Max. Box Volume Fridge (l)	150
Max. Box Volume Freezer (l)	50



230

320

100

CATEGORY	UNIT CODE	DESCRIPTION	CONTROL
Fridge	U150X000R11111AA	FRIDGE UNIT 150L OVAL EVAPORATOR 7,5L 320x100x230mm 12/24V (2301)	Mechanical
Fridge	U150X000R11111AB	FRIDGE UNIT 150L OVAL EVAPORATOR 7,5L 320x100x230mm 12/24V DC (2309) WITH EVAPORATOR DOOR	Mechanical
Fridge/freezer	U150X050R17161AA	FRIDGE/FREEZER UNIT 150/50L OVAL EVAPORATOR 7,5L 320x100x230mm 12/24V DC ITC (2301)	ITC
Fridge/freezer	U150X050R17151AA	FRIDGE/FREEZER UNIT 150/50L EVAPORATOR OVAL 7,5L 320x100x230mm 12/24V DC SEC (2301)	SEC

SPECIFICATIONS

Evaporator	275 x 220 x 70
Max. Box Volume Fridge (l)	150



275

70

220

CATEGORY	UNIT CODE	DESCRIPTION	CONTROL
Fridge	U150X000F11111AA	FRIDGE UNIT 150L FINS VENTILATED EVAPORATOR 150 L 275x220x70mm 12/24V DC	Mechanical

Air-cooled

Cooling Unit BD50F base

Select your control



Mechanical



ITC



SEC



160

330

175

SPECIFICATIONS

Evaporator	O
Max. Box Volume Fridge (l)	200
Max. Box Volume Freezer (l)	66



270

380

140

CATEGORY	UNIT CODE	DESCRIPTION	CONTROL
Fridge	U200X000R11111AA	FRIDGE UNIT 200L OVAL EVAPORATOR 14L 380x140x270mm 12/24V DC (2501)	Mechanical
Freezer	U000X066R13111AA	FREEZER UNIT 66L OVAL EVAPORATOR 14L 380x140x270mm 12/24V DC (2501)	Mechanical

SPECIFICATIONS

Evaporator	Flat
Max. Box Volume Fridge (l)	200
Max. Box Volume Freezer (l)	66



1200

190

CATEGORY	UNIT CODE	DESCRIPTION	CONTROL
Freezer	U000X066P13111AA	FREEZER UNIT 66L FLAT EVAPORATOR 1200x190mm 12/24V DC (2016)	Mechanical
Fridge/freezer	U200X066P12111AA	FRIDGE/FREEZER UNIT 200L/66L FLAT EVAPORATOR 1200x190mm 12/24V DC DUAL (2016)	Dual

SPECIFICATIONS

Evaporator	Flat
Max. Box Volume Fridge (l)	260
Max. Box Volume Freezer (l)	86

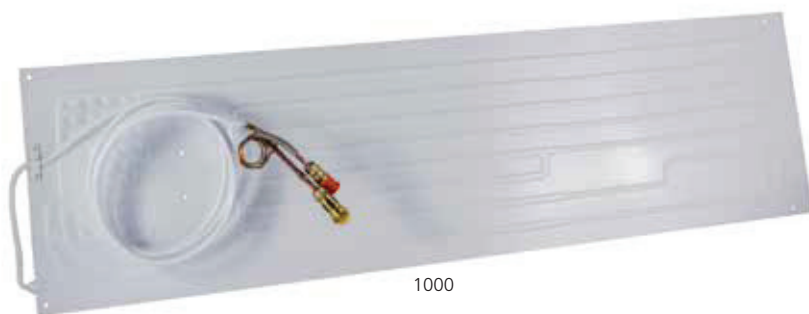

1000

270

CATEGORY	UNIT CODE	DESCRIPTION	CONTROL
Freezer	U000X086P13111AA	FREEZER UNIT 86L FLAT EVAPORATOR 1000x270mm 12/24V DC (2017)	Mechanical
Fridge/freezer	U260X086P12111AA	FRIDGE/FREEZER UNIT 260L/86L FLAT EVAPORATOR 1000x270mm 12/24V DC DUAL (2017)	Dual

Air-cooled

Cooling Unit BD50F base

Select your control



Mechanical



ITC



SEC



160

175

330

SPECIFICATIONS

Evaporator	Flat
Max. Box Volume Fridge (l)	400
Max. Box Volume Freezer (l)	133

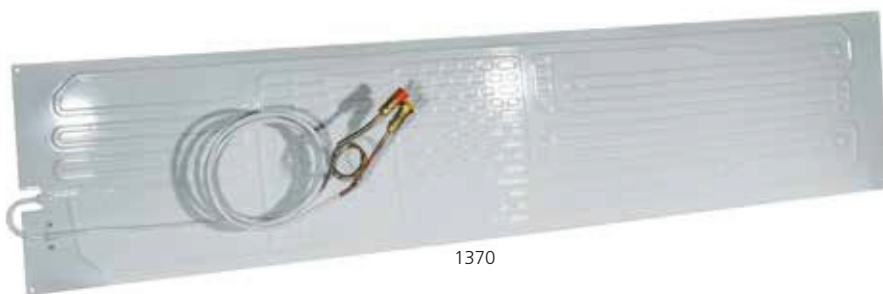

300

1370

CATEGORY	UNIT CODE	DESCRIPTION	CONTROL
Freezer	U000X133P13111AA	FREEZER UNIT 133L FLAT EVAPORATOR 1370x300mm 12/24V DC (2013)	Mechanical
Fridge/freezer	U400X133P12111AA	FRIDGE/FREEZER UNIT 400L/133L FLAT EVAPORATOR 1370x300mm 12/24V DC DUAL (2013)	Dual

SPECIFICATIONS

Evaporator	Flat
Max. Box Volume Fridge (l)	170
Max. Box Volume Freezer (l)	56



210

815

CATEGORY	UNIT CODE	DESCRIPTION	CONTROL
Fridge/freezer	U170X056P12111AA	FRIDGE/FREEZER UNIT 170L/56L FLAT EVAPORATOR 815x210mm 12/24V DC DUAL (2012)	Dual
Fridge/freezer	U170X056P17161AA	FRIDGE/FREEZER UNIT 170/56L FLAT EVAPORATOR 815x210mm 12/24V DC ITC (2012)	ITC

Water-cooled SP

Cooling Unit BD35F base

Select your control



Mechanical



ITC



SEC



SPECIFICATIONS	
Evaporator	L
Max. Box Volume Fridge (l)	100



CATEGORY	UNIT CODE	DESCRIPTION	CONTROL
Fridge	U100X000L11311AA	FRIDGE UNIT 100L SP "L" BENT EVAPORATOR 250+110x350mm 12/24V DC (2057)	Mechanical

SPECIFICATIONS	
Evaporator	Flat
Max. Box Volume Fridge (l)	170
Max. Box Volume Freezer (l)	56

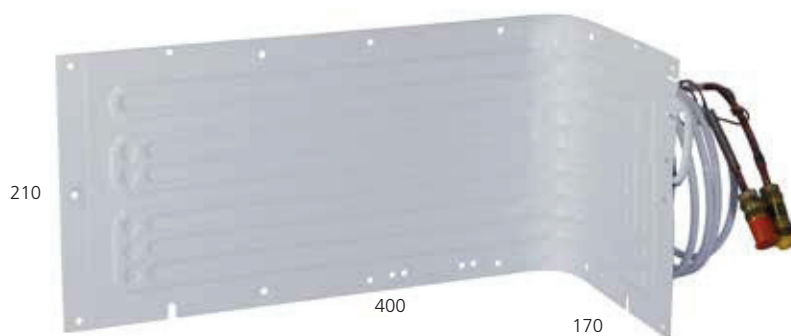

CATEGORY	UNIT CODE	DESCRIPTION	CONTROL
Fridge	U125X000L11311AA	FRIDGE UNIT 125L SP "L" BENT EVAPORATOR 400+170x210mm 12/24V DC (2050)	Mechanical
Fridge	U000X041L13311AA	FREEZER UNIT 41L SP "L" BENT EVAPORATOR 400+170x210mm 12/24V DC (2050)	Mechanical

SPECIFICATIONS	
Evaporator	O
Max. Box Volume Fridge (l)	125

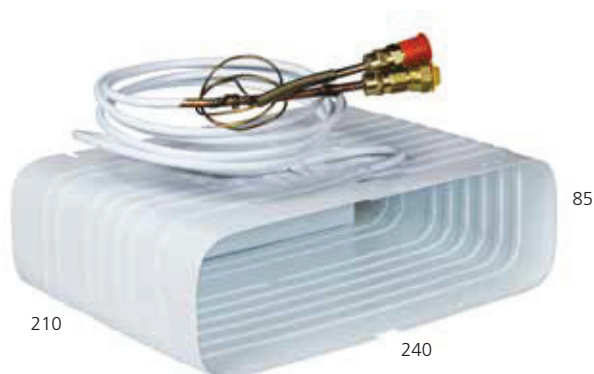

CATEGORY	UNIT CODE	DESCRIPTION	CONTROL
Fridge	U125X000R11311AA	FRIDGE UNIT 125L SP OVAL EVAPORATOR 4L 240x210x85mm 12/24V DC (2051)	Mechanical

Water-cooled SP

Cooling Unit BD35F base

Select your control



Mechanical



ITC



SEC

175

160

280



SPECIFICATIONS

Evaporator	O
Max. Box Volume Fridge (l)	150



230

320

100

CATEGORY	UNIT CODE	DESCRIPTION	CONTROL
Fridge	U150X000R11311AA	FRIDGE UNIT 150L SP OVAL EVAPORATOR 7,5L 320x100x230mm 12/24V DC (2351)	Mechanical

Water-cooled Magnum

Cooling Unit BD50F base

Select your control

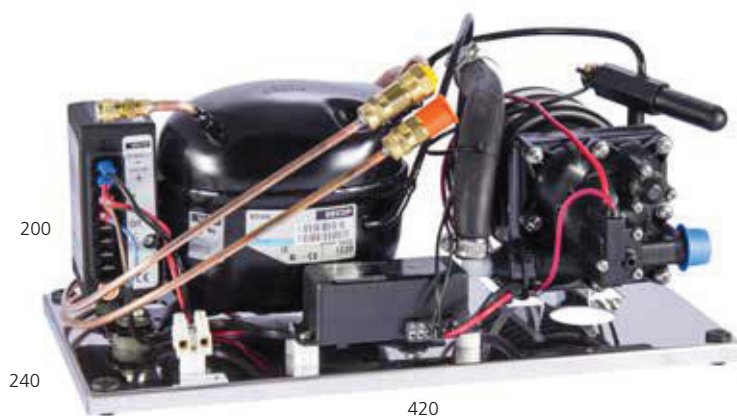

SPECIFICATIONS

Evaporator	O
Max. Box Volume Fridge (l)	200
Max. Box Volume Freezer (l)	66



CATEGORY	UNIT CODE	DESCRIPTION	CONTROL
Fridge/freezer	U200X066R12411AA	FRIDGE/FREEZER UNIT 200L/66L MAGNUM OVAL EVAPORATOR 14L 380x140x270mm 12/24V DC DUAL (2505)	Dual

SPECIFICATIONS

Evaporator	Flat
Max. Box Volume Fridge (l)	260
Max. Box Volume Freezer (l)	86

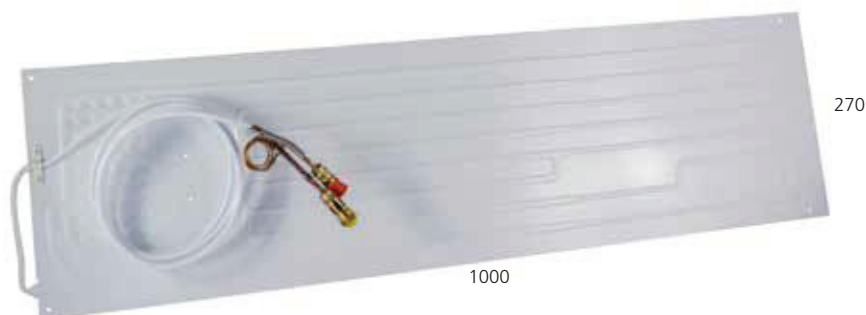

CATEGORY	UNIT CODE	DESCRIPTION	CONTROL
Fridge/freezer	U260X086P12411AA	FRIDGE/FREEZER UNIT 260L/86L MAGNUM FLAT EVAPORATOR 1000x270mm 12/24V DC DUAL (2513)	Dual

SPECIFICATIONS

Evaporator	Flat
Max. Box Volume Fridge (l)	400
Max. Box Volume Freezer (l)	133



CATEGORY	UNIT CODE	DESCRIPTION	CONTROL
Fridge/freezer	U260X086P12411AA	FRIDGE/FREEZER UNIT 400L/133L MAGNUM FLAT EVAPORATOR 1370x300mm 12/24V DC DUAL (2507)	Dual

Water-cooled Magnum

Cooling Unit BD80F base

Select your control



Mechanical



ITC



SEC

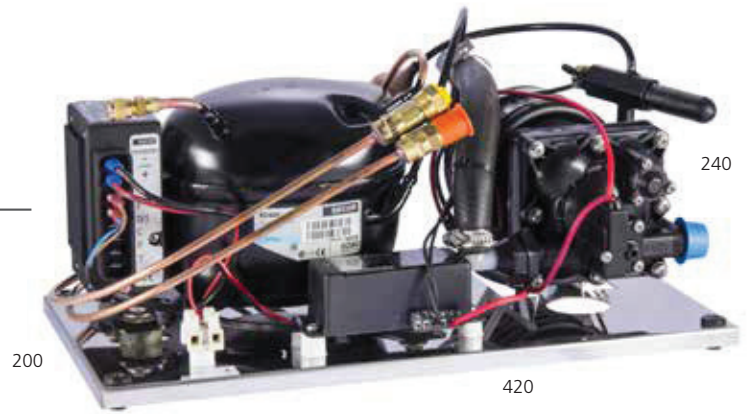

SPECIFICATIONS

Evaporator	Flat
Max. Box Volume Freezer (l)	141

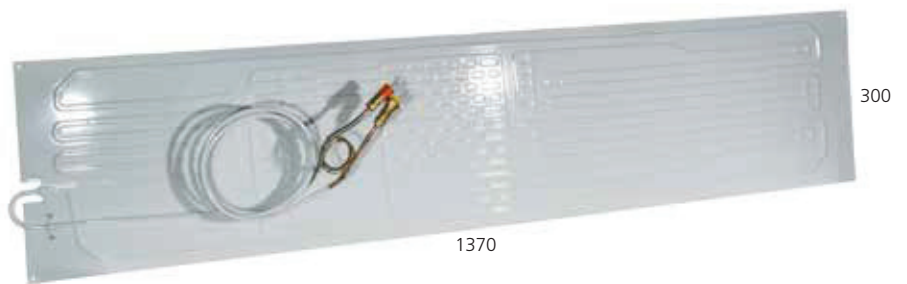

CATEGORY	UNIT CODE	DESCRIPTION	CONTROL
Freezer	U000X141P13411AA	FREEZER UNIT 141L MAGNUM FLAT EVAPORATOR 1370x300mm 12/24V DC (2607)	Mechanical

SPECIFICATIONS

Evaporator	Flat
Max. Box Volume Freezer (l)	200

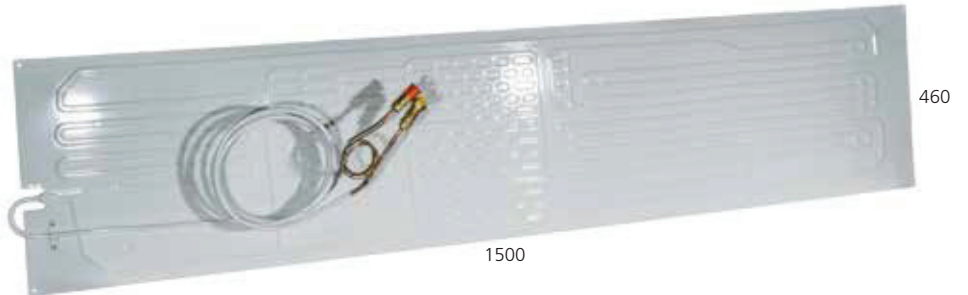

CATEGORY	UNIT CODE	DESCRIPTION	CONTROL
Freezer	U000X200P13411AA	FREEZER UNIT 200L MAGNUM FLAT EVAPORATOR 1500x460mm 12/24V DC (2609)	Mechanical

Cooling Unit ITC+

Air-Cooled

SPECIFICATIONS

Plate	2L
Max. Box Volume Fridge (l)	100
Max. Box Volume Freezer (l)	35

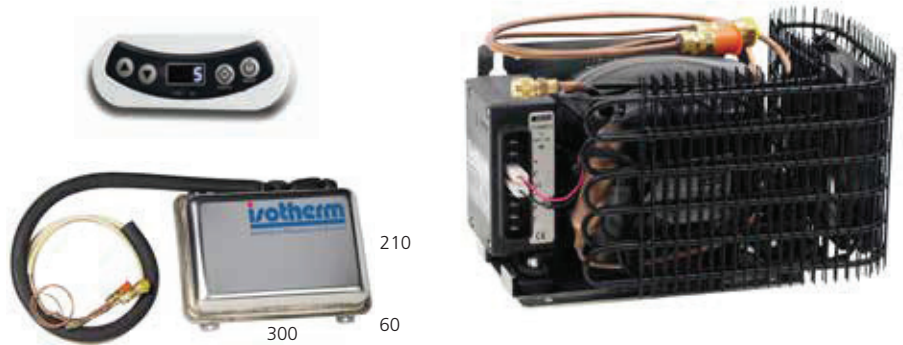

CATEGORY	UNIT CODE	COMPRESSOR	DESCRIPTION	CONTROL
Fridge/freezer	U100X035A17161AA	BD35F	FRIDGE/FREEZER UNIT 100L/35L HOLDING PLATE 2L 12/24V DC ITC+ (3201)	ITC+

SPECIFICATIONS

Plate	3L
Max. Box Volume Fridge (l)	150
Max. Box Volume Freezer (l)	50



CATEGORY	UNIT CODE	COMPRESSOR	DESCRIPTION	CONTROL
Fridge/freezer	U150X050A17161AA	BD50F	FRIDGE/FREEZER UNIT 150L/50L HOLDING PLATE 3L 12/24V DC ITC+ (3701)	ITC+

SPECIFICATIONS

Plate	6L
Max. Box Volume Fridge (l)	200
Max. Box Volume Freezer (l)	65



CATEGORY	UNIT CODE	COMPRESSOR	DESCRIPTION	CONTROL
Fridge/freezer	U200X065A17161AA	BD50F	FRIDGE/FREEZER UNIT 200L/65L HOLDING PLATE 6L 12/24V DC ITC+	ITC+

Cooling Unit ITC+

Water Cooled SP

SPECIFICATIONS

Plate	2L
Max. Box Volume Fridge (l)	100
Max. Box Volume Freezer (l)	35



CATEGORY	UNIT CODE	COMPRESSOR	DESCRIPTION	CONTROL
Fridge/freezer	U100X035A17361AA	BD35F	FRIDGE/FREEZER 100L/35L SP HOLDING PLATE 2L 12/24V DC ITC+ (3251)	ITC+

SPECIFICATIONS

Plate	3L
Max. Box Volume Fridge (l)	150
Max. Box Volume Freezer (l)	50



CATEGORY	UNIT CODE	COMPRESSOR	DESCRIPTION	CONTROL
Fridge/freezer	U150X050A17361AA	BD50F	FRIDGE/FREEZER UNIT 150L/50L SP HOLDING PLATE 3L 12/24 ITC+ (3751)	ITC+

SPECIFICATIONS

Plate	3L
Max. Box Volume Fridge (l)	150
Max. Box Volume Freezer (l)	50



CATEGORY	UNIT CODE	COMPRESSOR	DESCRIPTION	CONTROL
Fridge/freezer	U200X065A17361AA	BD50F	FRIDGE/FREEZER UNIT 200L/65L SP HOLDING PLATE 6L 12/24 ITC+	ITC+

Cooling Unit ITC+

Water Cooled Magnum

SPECIFICATIONS

Plate	3L
Max. Box Volume Fridge (l)	150
Max. Box Volume Freezer (l)	50



CATEGORY	UNIT CODE	COMPRESSOR	DESCRIPTION	CONTROL
Fridge/freezer	U150X050A17461AA	BD50F	FRIDGE/FREEZER UNIT 150L/50L MAGNUM HOLDING PLATE 3L 12/24 DC ITC+ (4201)	ITC+

SPECIFICATIONS

Plate	3L
Max. Box Volume Fridge (l)	150
Max. Box Volume Freezer (l)	50



CATEGORY	UNIT CODE	COMPRESSOR	DESCRIPTION	CONTROL
Fridge/freezer	U200X065A17461AA	BD50F	FRIDGE/FREEZER UNIT 200/65L MAGNUM HOLDING PLATE 6L 12/24 DC ITC+ (4701)	ITC+

Build your own cooler box!

Build a box into your boat. It's not difficult at all! Most boats have one thing in common. They have very few right angles or regular shaped compartments. This often makes it difficult to find space for a fridge or cooler. But no worries. Indel Webasto Marine offers do it yourself refrigeration or freezing boxes!

Indel Webasto Marine can supply a flat-pack set of ready-cut insulated panels to help build a customised box. The panels are covered on both sides with 2.5 mm plastic laminate of foodstuff quality and have 46 mm thick closed cell foam insulation in between. They are easy to cut and glue together using a polyurethane sealant or mould resistant silicone resulting in joints that are leak-proof but not totally inflexible.

The kit REF. SCD00001AA, consists of three insulation panels measuring 978 x 478 x 50 mm, cover strips for the edges of the lid as well as a user-friendly instruction manual.

Cooling evaporators are available in a number of designs: the O-shaped serves for freezer compartments but requires slightly more space. The L- and flat-shaped can be bent to fit the box. These require less space and produce a slightly more even temperature distribution in the box, but do not have a freezer compartment. The evaporators can be fitted in any position. They are delivered with 2 meter pipes, have quick-couplings and require an installation opening of not more than \varnothing 30 mm in the refrigerator wall. The desired temperature is adjusted with a thermostat. A cooling and ventilation fan is fitted to all our air-cooled models for highest efficiency.

Find the right evaporator:

Isotherm Large and Jumbo evaporators have extra large freezing surface that can be bent so that cooling energy can be radiated from all four sides. The Isotherm Magnum model is available with a holding plate suitable for freezer and adjustable to -6°C , but it produces less stable temperature compared to the radiation type evaporator.

To achieve stable freezing temperatures within the box, we recommend the powerful Large or Jumbo evaporators. To determine the ideal size of evaporator for your boat, divide the recommended maximum volume by three. The size of evaporator should be chosen under the consideration to have at least two mounted to the sides of the box. The evaporator, which is made of malleable aluminum enabling it to be shaped to perfectly fit the inside of most of the boxes, (please always refer to our installation manual for detailed information), is available for freezers of up to 175 liters. Always specify the final use of the unit (fridge or freezer use).

Temperature is regulated with a traditional thermostat. For high-efficiency freezing, large covering evaporators are required. The ITC+ feature is not recommended in this application.

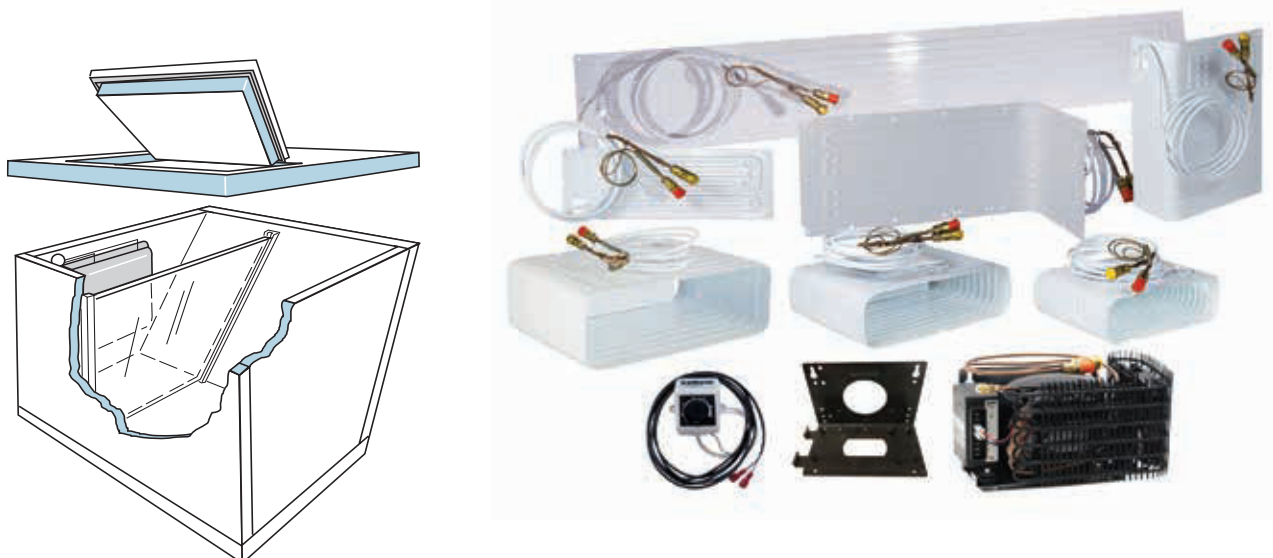

Cooling Units Accessories:

Picture	Order Number	Description
	SEG00030GA	ELECTRONIC UNIT DANFOSS/SECOP BD35F/50FAC/DC 12/24V-115/230V
	SEH00004HA	Power pack 110/240 V AC 47/63 Hz IN 24 V DC 4,2 A OUT for BD35F/BD50F
	SEC00003DA	Internal light kit 12 – 24 V
	SBE00004AA	Air hose adapter kit Ø 106 mm (l = 1.500 mm)
	SGE00012AA	"Click-on" bracket for an easy compressor' installation
	SEA00076DA	High speed Thermostat kit for freezers
	SBD00031AA	Extension tube with couplings (l = 1 m)
	SBD00032AA	Extension tube with couplings (l = 2 m)
	SBD00033AA	Extension tube with couplings (l = 3 m)
	SBE00006AA	Zinc anode for sea water-cooled SP units

Picture	Order Number	Description
	SBE00008AA	Zinc anode, 3/8", for sea water-cooled Magnum units
	SGC00005AA	Evaporator door O-SMALL
	SGC00004AA	Evaporator door O-MEDIUM
	SGC00003AA	Evaporator door O-BIG
	SEA00004DB	Double thermostat kit, 10 °C to -20 °C
	SFD00008AA	Skin fitting valve kit for SP units
	SBE00071CA	Air circulation fan
	SGC00152AA	Foldable bottle rack
	SGC00006AA	Ice cube kit for holding plate